

NOTICE DE MONTAGE ET D'UTILISATION ASSEMBLY AND USAGE INSTRUCTIONS

DAXARA by erde
- 239x4

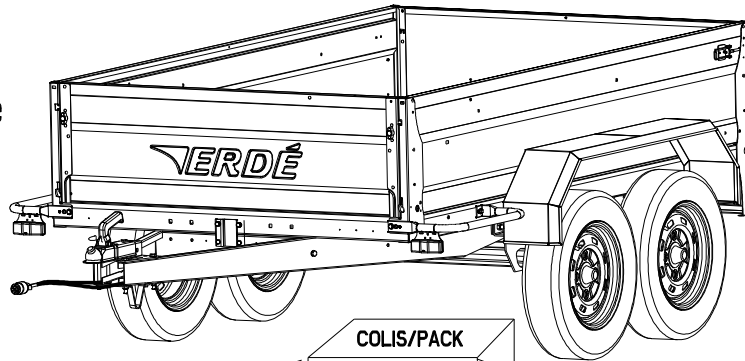

ERDE
- 234x4

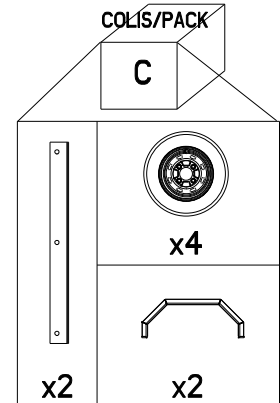
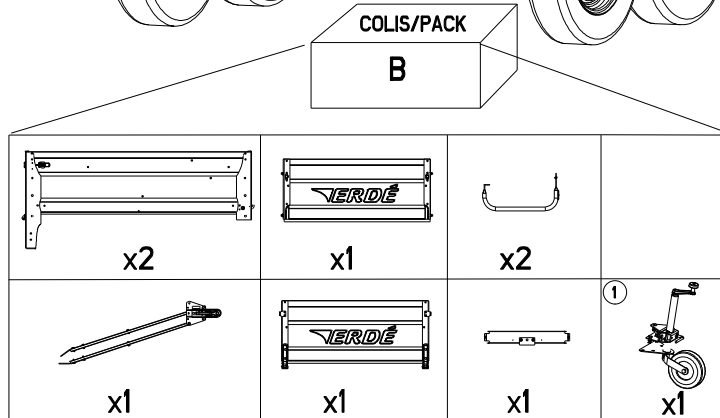
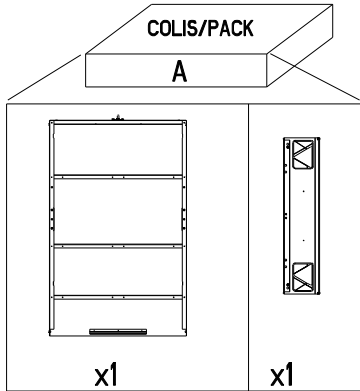

SACHET DE VIS / NUTS AND BOLTS CONTENT

x2	x20	x14	x2	x2	x10
HM 10x25	HM 8x25	HM 12x35	HM 8x35	HM 6x12	FR HM 12
x4	x 14	x4	x2	x1	x1
CLIP	∅12	∅12	∅10	GOUILLE/RCLIP	GOND/HINGE
x1	x2	x2	x2		
GOND/HUNG	ANNEAU/RING	∅8	∅8		
① SACHET SUPPORT RJ / JOCKEY WHEEL CONTENT					
x3	x2	x3			
HM 10x25	∅10	FR HM 10			

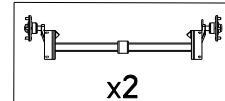

PORTER DES GANTS POUR LE MONTAGE.
WEAR GLOVES FOR THE ASSEMBLY

OUTILS NECESSAIRES POUR LE MONTAGE NON FOURNIS
NECESSARY TOOLS FOR ASSEMBLY NOT PROVIDED

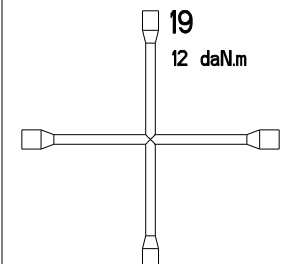
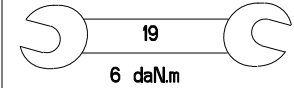
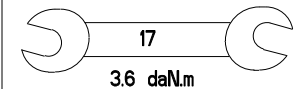
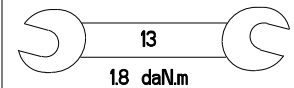
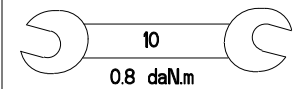





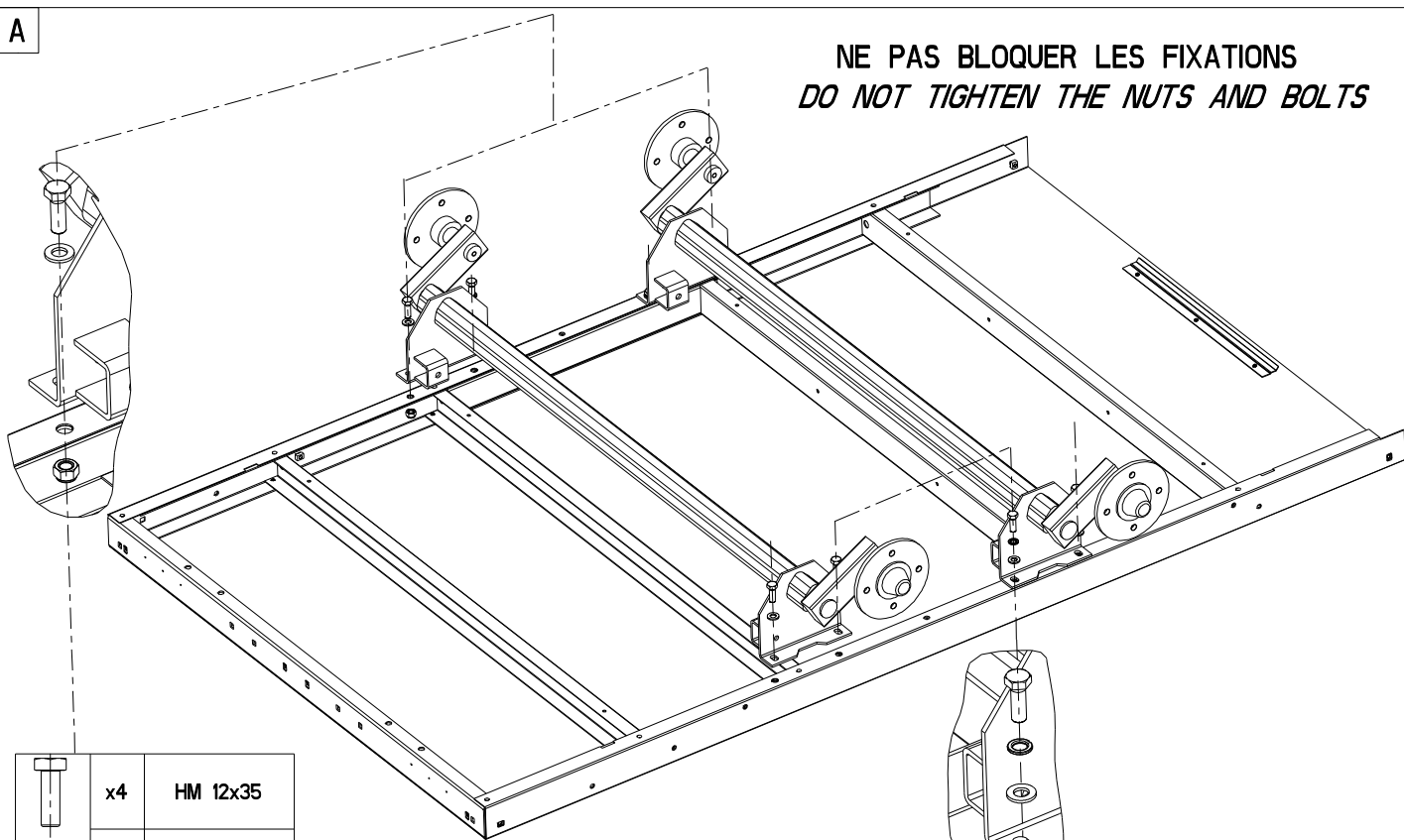

① UNIQUEMENT SUR MODELES DAXARA
ONLY ON DAXARA MODELS

A



NE PAS BLOQUER LES FIXATIONS
DO NOT TIGHTEN THE NUTS AND BOLTS



	x4	HM 12x35
	x4	Ø12
	x4	FR HM 12

	x4	HM 12x35
	x4	Ø12
	x4	Ø12

B

		
x4	x4	x4
HM 12x35	Ø12	FR HM 12

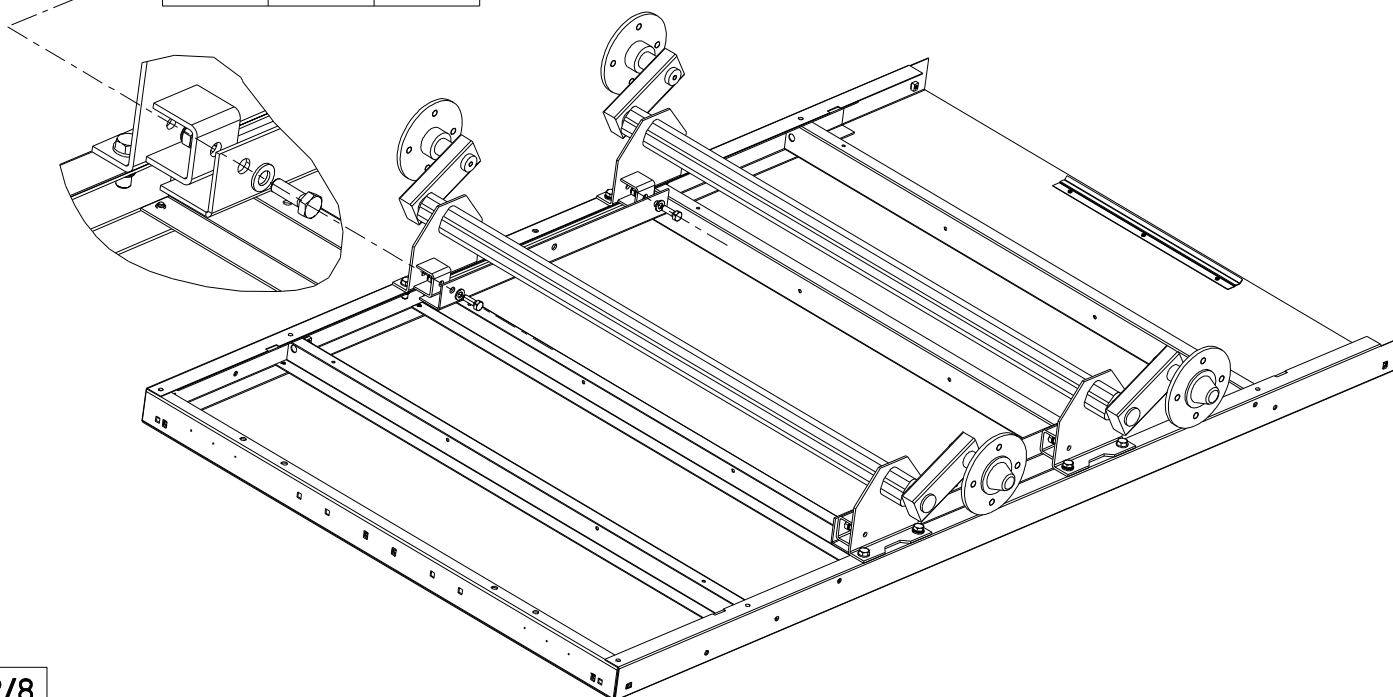

C

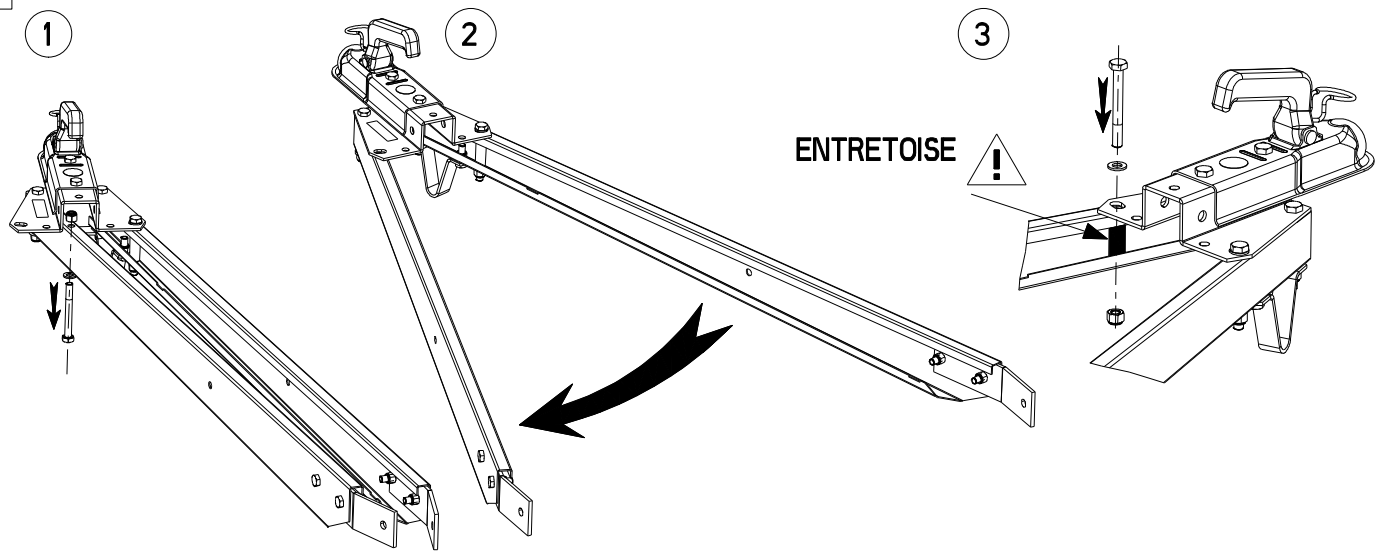

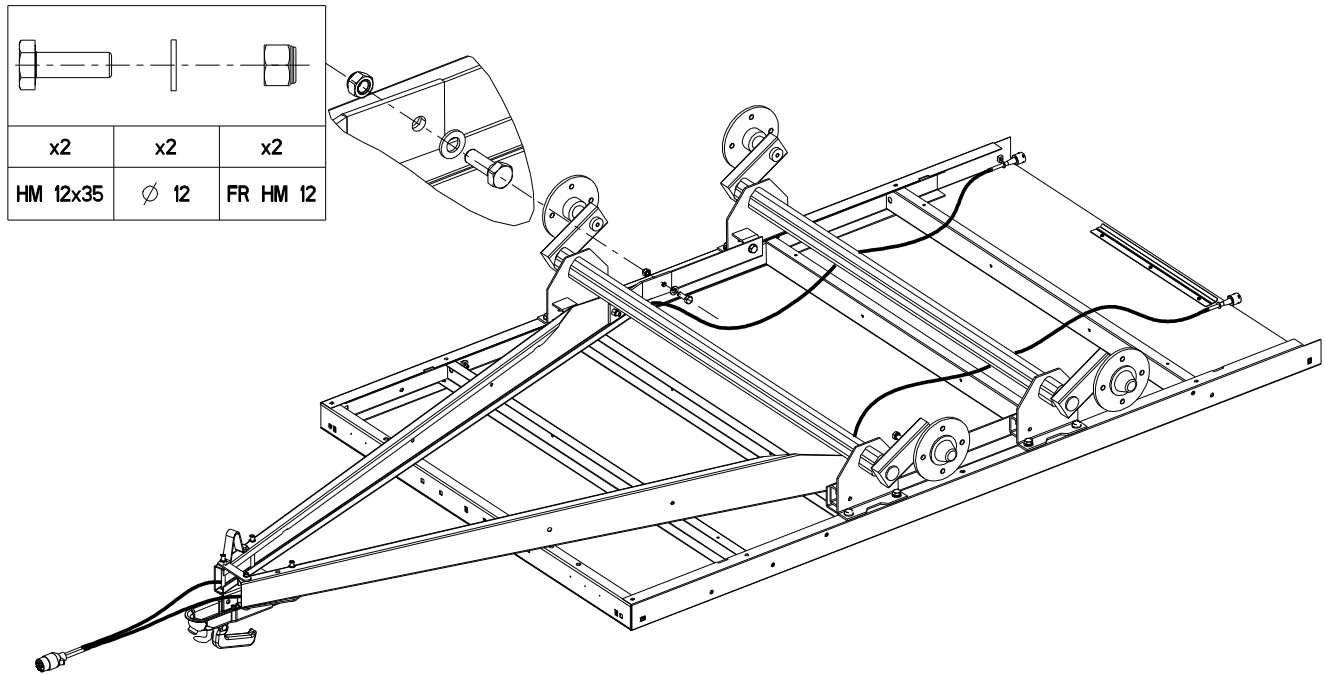

D



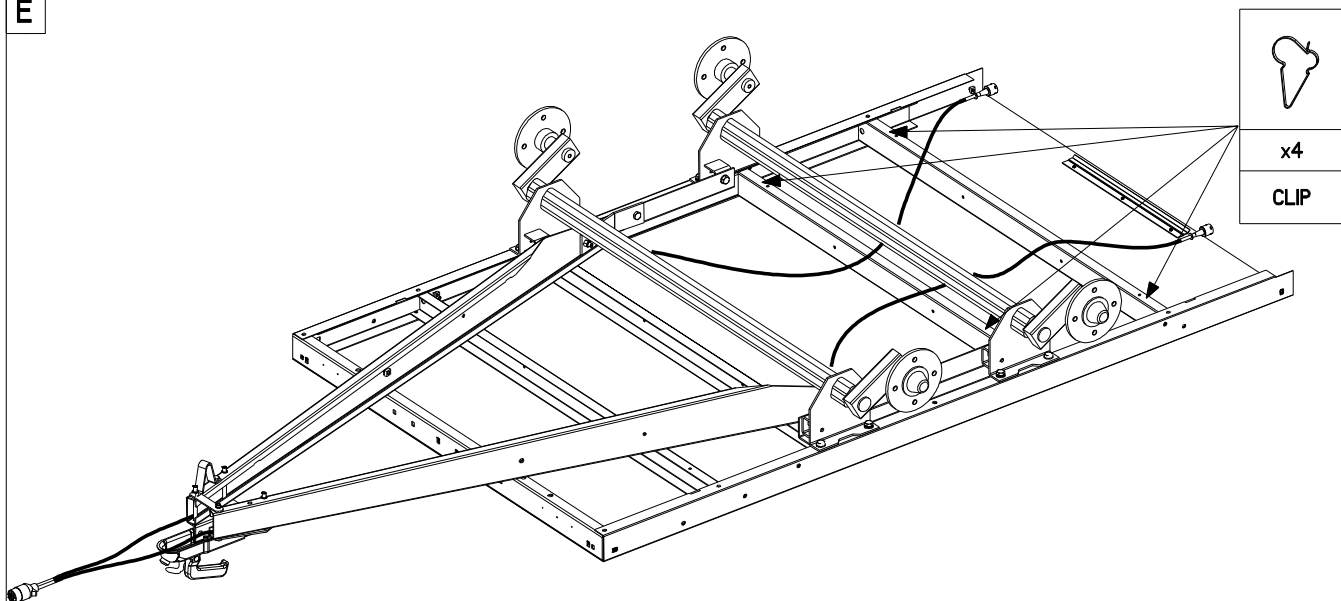

E

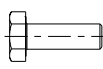

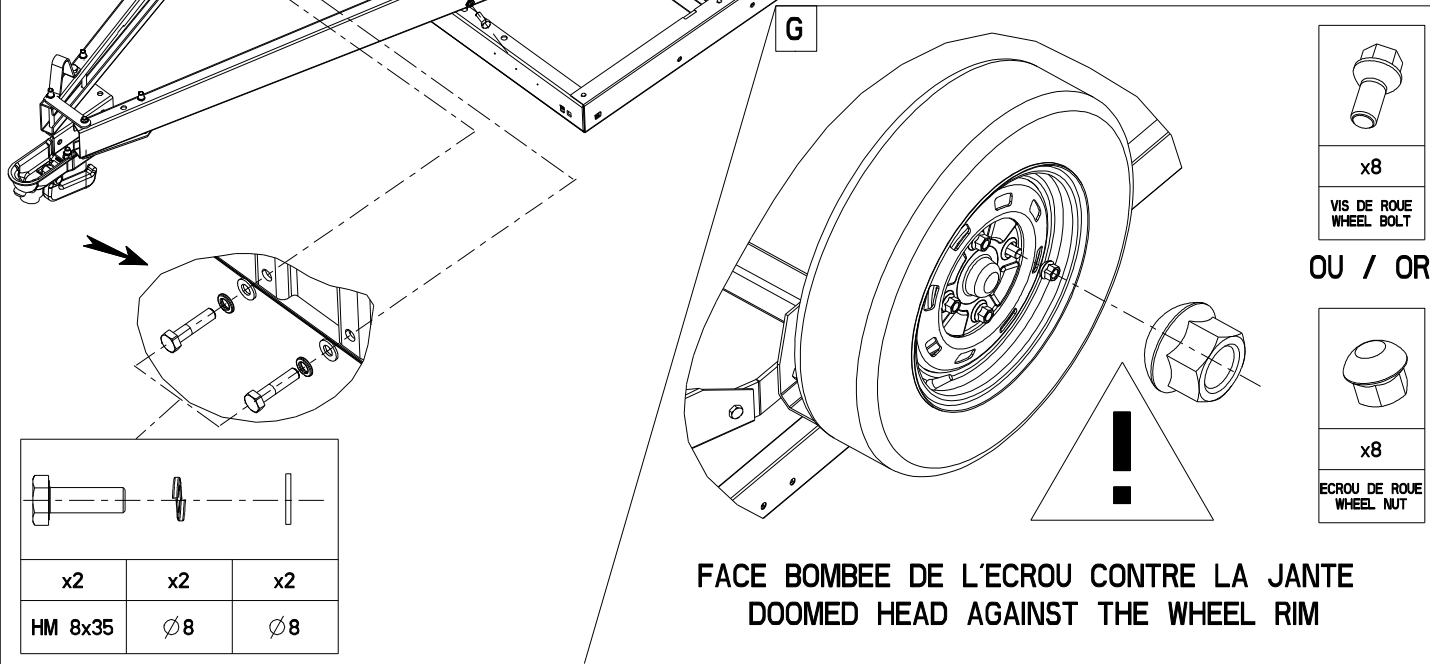

F BLOQUER LES FIXATIONS
APRES CETTE OPERATION
*TIGHTEN ALL NUTS AND BOLTS
AT THIS STAGE*

	
x2	x2
HM 10x25	Ø10

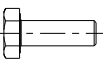

x8
VIS DE ROUE WHEEL BOLT
OU / OR

x8
ECROU DE ROUE WHEEL NUT

		
x2	x2	x2
HM 8x35	Ø8	Ø8

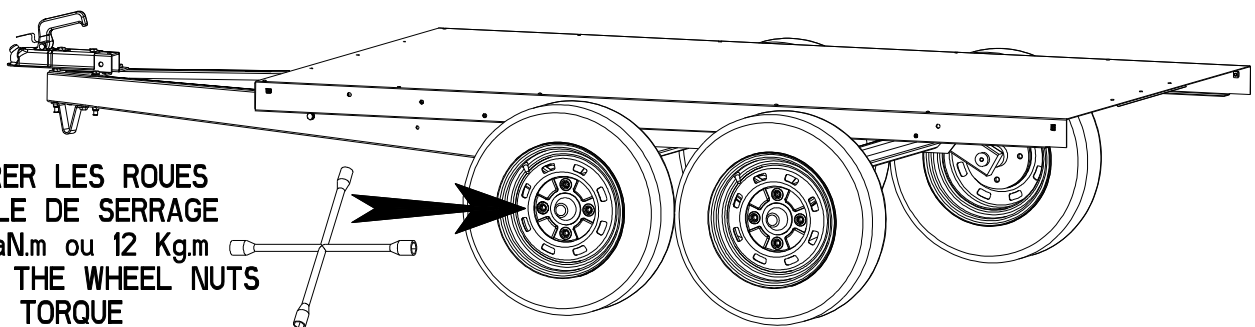
H ① RETOURNER LA REMORQUE
TURN OVER THE TRAILER



② SERRER LES ROUES
COUPLE DE SERRAGE
12 daN.m ou 12 Kg.m
TIGHTEN THE WHEEL NUTS
TORQUE
12 daN.m ou 12 Kg.m

POUR LES REMORQUES EQUIPEES D'UNE ROUE JOCKEY DE SERIE, VEUILLEZ VOUS REPORTER A LA NOTICE DE MONTAGE "ROUE JOCKEY" OPERATION 3 (JOINTE), AVANT D'EFFECTUER ILES OPERATIONS SUIVANTES.
FOR TRAILER WITH JOCKEY WHEELS FITTED AS STANDARD PLEASE REFER TO THE ASSEMBLY INSTRUCTIONS FOR "JOCKEY WHEELS" OPERATION 3 BEFORE CARRYING THE FOLLOWING OPERATION.

I

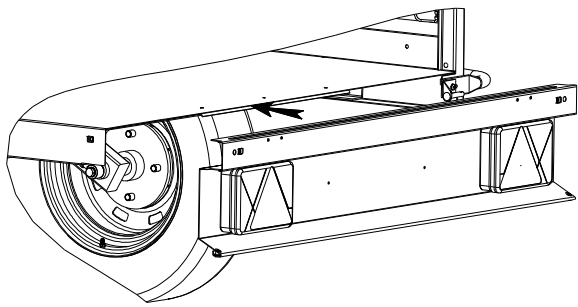

1

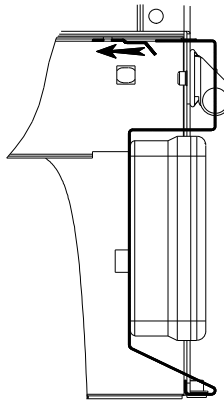

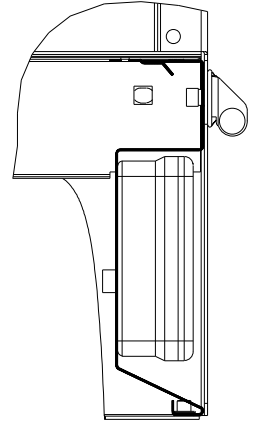

2

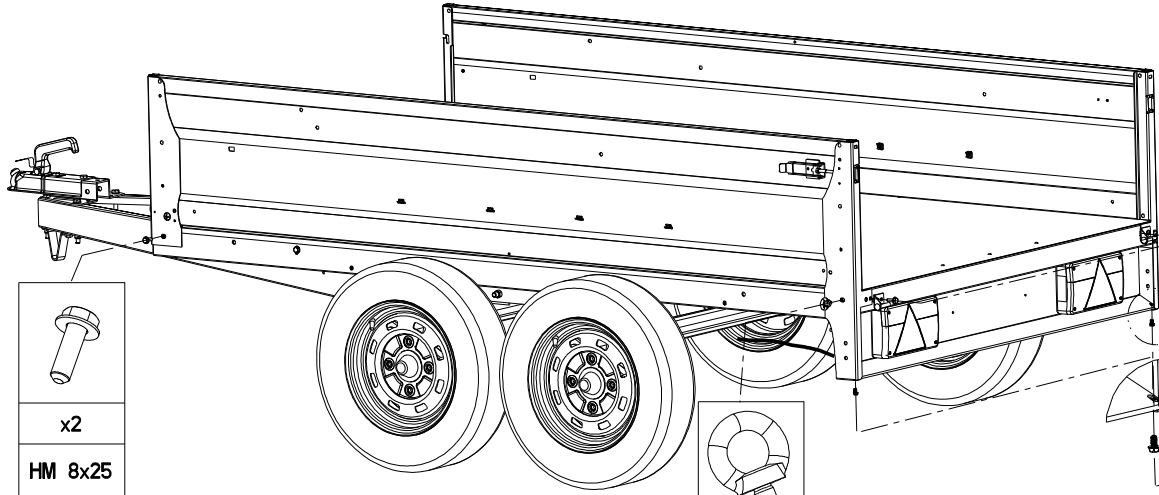

J

NE PAS BLOQUER LES FIXATIONS DES OPERATIONS SUIVANTES
 DO NOT TIGHTEN THE NUTS AND BOLTS DURING THE NEXT SEQUENCES

x2
HM 8x25



x2
ANNEAU





x2
HM 8x25

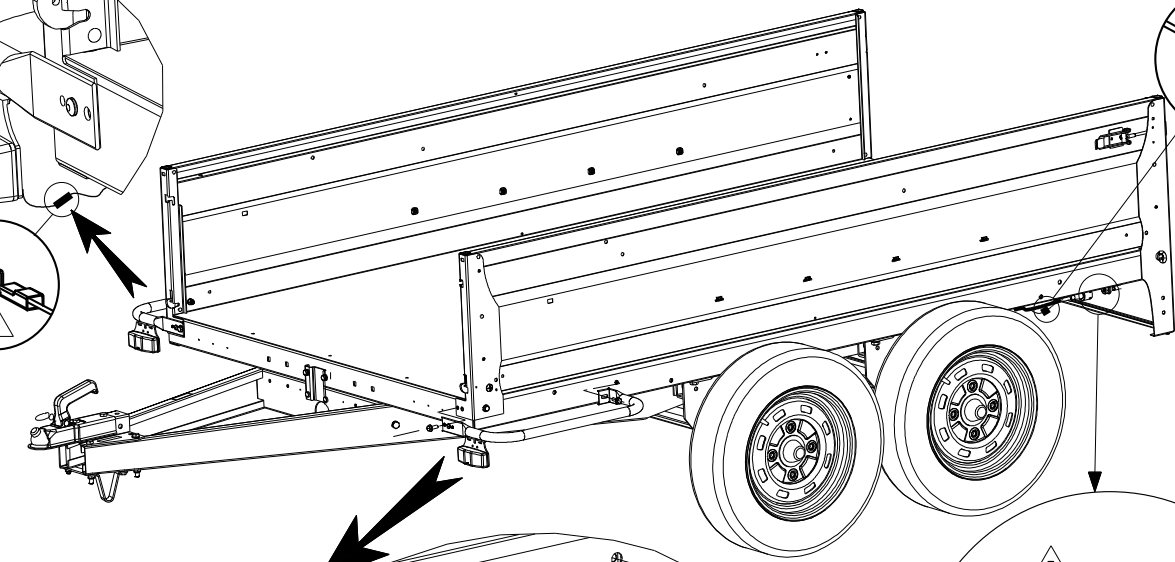
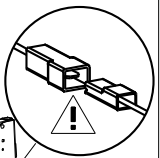
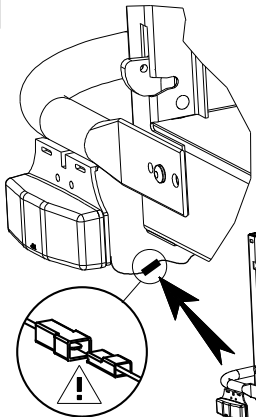

x2
HM 6x12

K

x2
HM 8x25



x2
HM 8x25

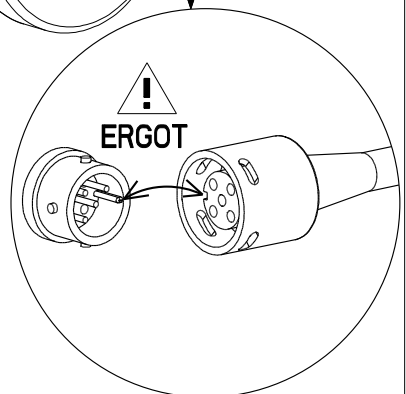

L

SYSTEME CLIC/CLAC

CE SYSTEME CLIC/CLAC DOIT ETRE UTILISE
EXCLUSIVEMENT EN POSITION FERMEE ET
VERROUILLEE OU RIDELLE AVANT COMPLETEMENT
RETIREE. L'UTILISATION EN POSITION INTERMEDIAIRE
N'EST PAS AUTORISEE.

CLICK/CLACK SYSTEM

THE " CLICK-CLACK " SYSTEM MUST BE USED
EITHER COMPLETELY CLOSED AND SECURED
WITH THE RCLIP. OR PERFECTLY STORED AND
SCREWED ALONG THE SIDE PANEL.

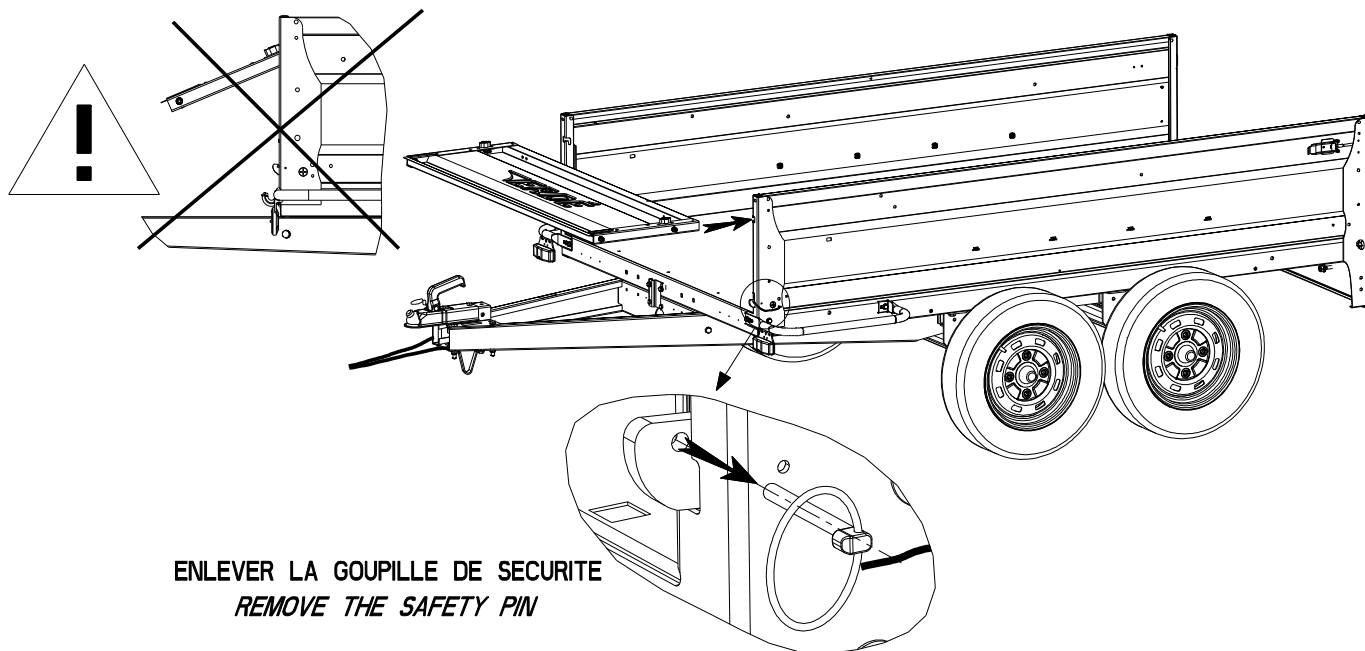

M

① CLIC / CLICK

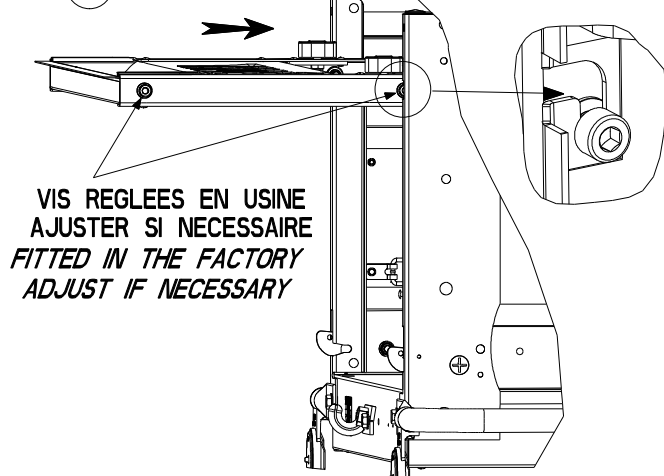

②

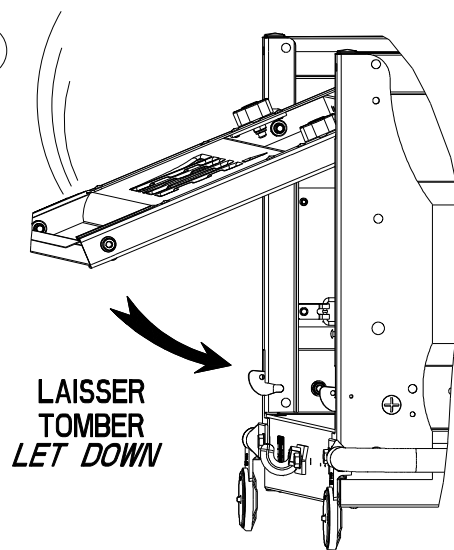

③

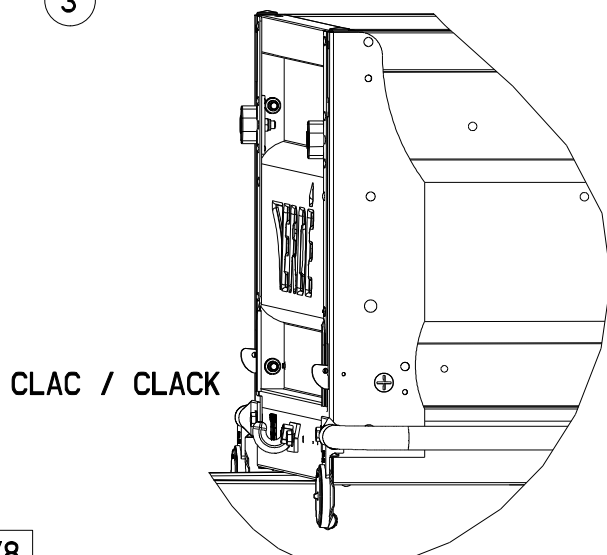

④

REMETTRE LA GOUPILLE DE SECURITE
DO NOT FORGET THE SAFETY PIN

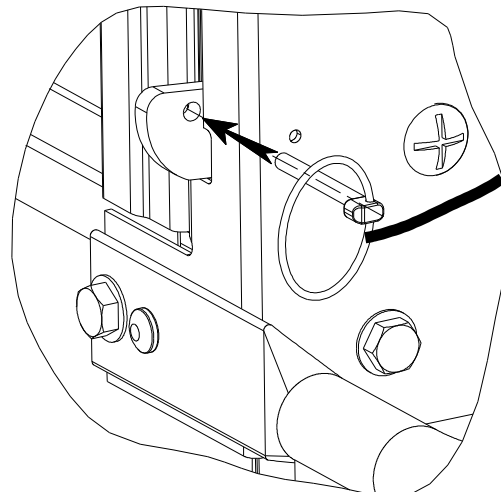



x8

HM 8x25



x4

HM 8x25

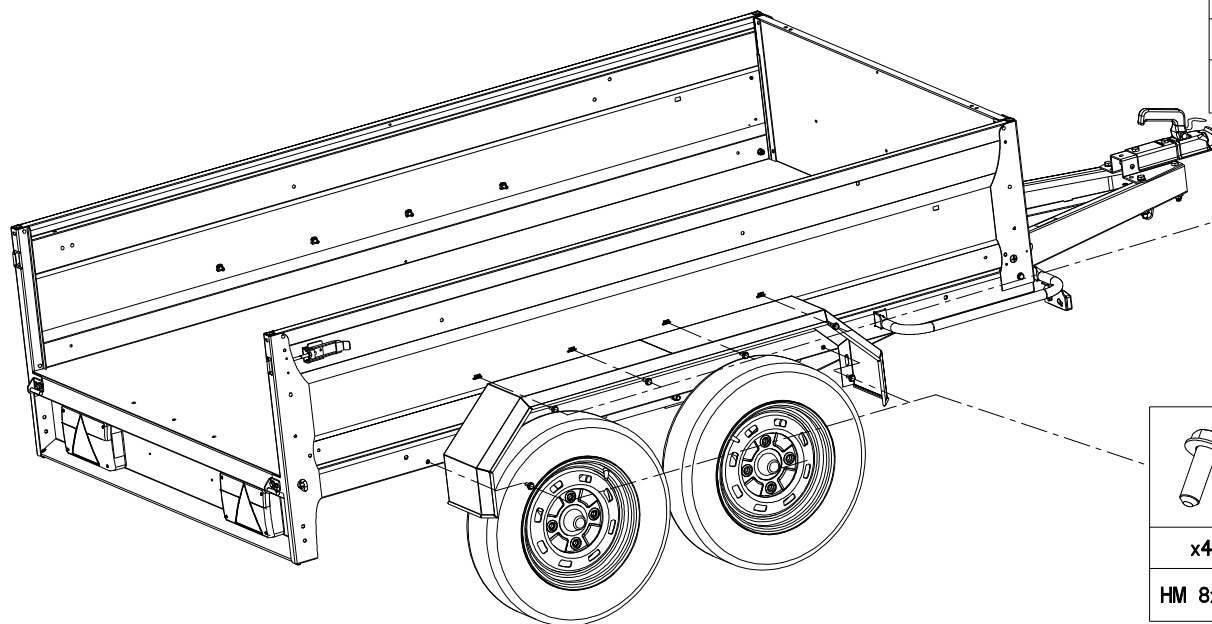

O

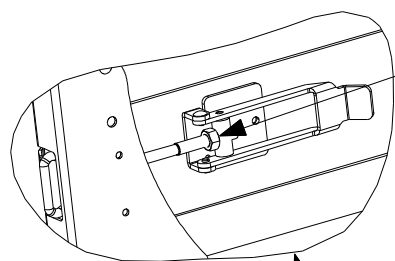

2

**REGLER LES SAUTERELLES
ET BLOQUER LES ECREUS
ADJUST THE LEAVERS
AND TIGHTEN THE NUTS AND BOLTS**

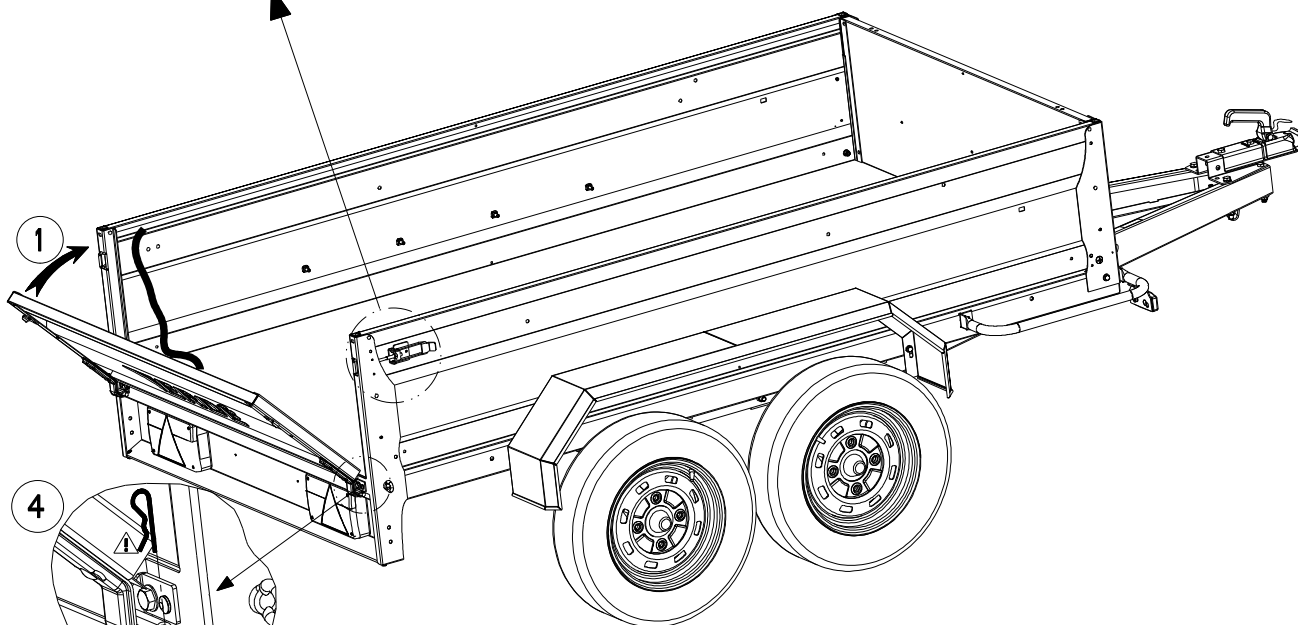

1

4

3

**BLOQUER TOUTES LES FIXATIONS EN COMMENCANT
PAR LES VIS LATERALES.
NE PAS OUBLIER DE SERRER LES VIS DES GONDS
APRES AVOIR RETIRE LA RIDELLE ARRIERE.**

**TIGHTEN ALL THE NUTS AND BOLTS STARTING
WITH THE SIDE PANELS.
DO NOT TIGHTEN THE HINGE SCREWS AFTER
TAKING OUT THE REAR PANEL**

P

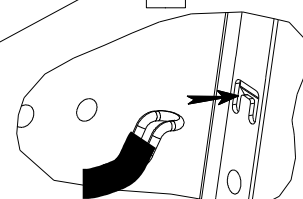

**INSERER LA CHAINE SUR LA RIDELLE ARRIERE
FIT THE CHAIN AS SHOWN ON THE REAR PANEL**

OUVERTURE DE LA RIDELLE AVANT ET FIXATION SUR RIDELLE LATÉRALE HOW TO OPEN THE FRONT DOOR AND INSTALL IT ON THE SIDE PANEL

