

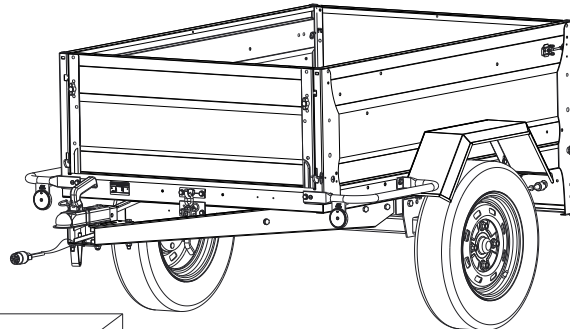

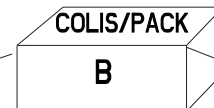

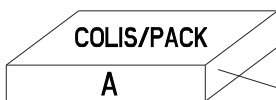



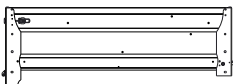

# NOTICE DE MONTAGE ET D'UTILISATION ASSEMBLY AND USAGE INSTRUCTIONS

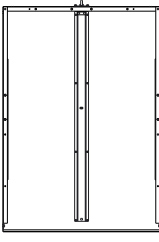
ERDE  
- 153.2



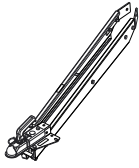

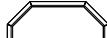
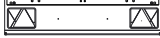







DAXARA by ERDE  
- 158.2



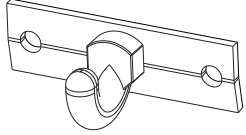
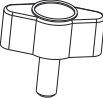

 x2	 x1	 x1	 x2	 x2	 x1	 x1
 x2	 x1		 x2	 x1	 x1	

SACHET DE VIS REMORQUE / NUTS AND BOLTS CONTENT

				
x6	x16	x2	x2	x2
HM 10x25	HM 8x25	HM 12x30	ANNEAU RING	HM 6x12
				
x2	x 2	x4	x6	x1
FR HM 12	∅12	∅10	∅10	GOUPILLE RCLIP
				
x4	x1		x2	
CLIP RCLIP	CROCHET/HOOK		MOLETTE SCREW KNOB	

① SACHET SUPPORT RJ / JOCKEY WHEEL CONTENT

				
x3	x2	x3		
HM 10x25	∅10	FR HM 10		

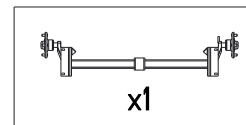

 PORTER DES GANTS POUR LE MONTAGE  
WEAR GLOVES FOR THE ASSEMBLY.

OUTILS NECESSAIRES POUR LE MONTAGE NON FOURNIS.  
NECESSARY TOOLS FOR ASSEMBLY. NOT PROVIDED.

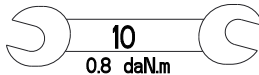
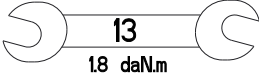
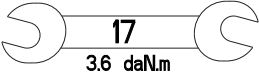
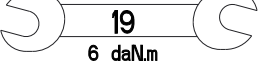
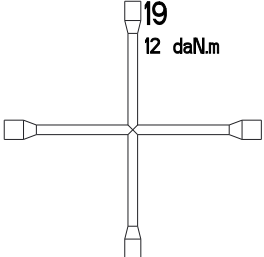
	10 0.8 daNm
	13 18 daNm
	17 3.6 daNm
	19 6 daNm
	19 12 daNm

① uniquement sur modèles DAXARA.  
only on DAXARA models.

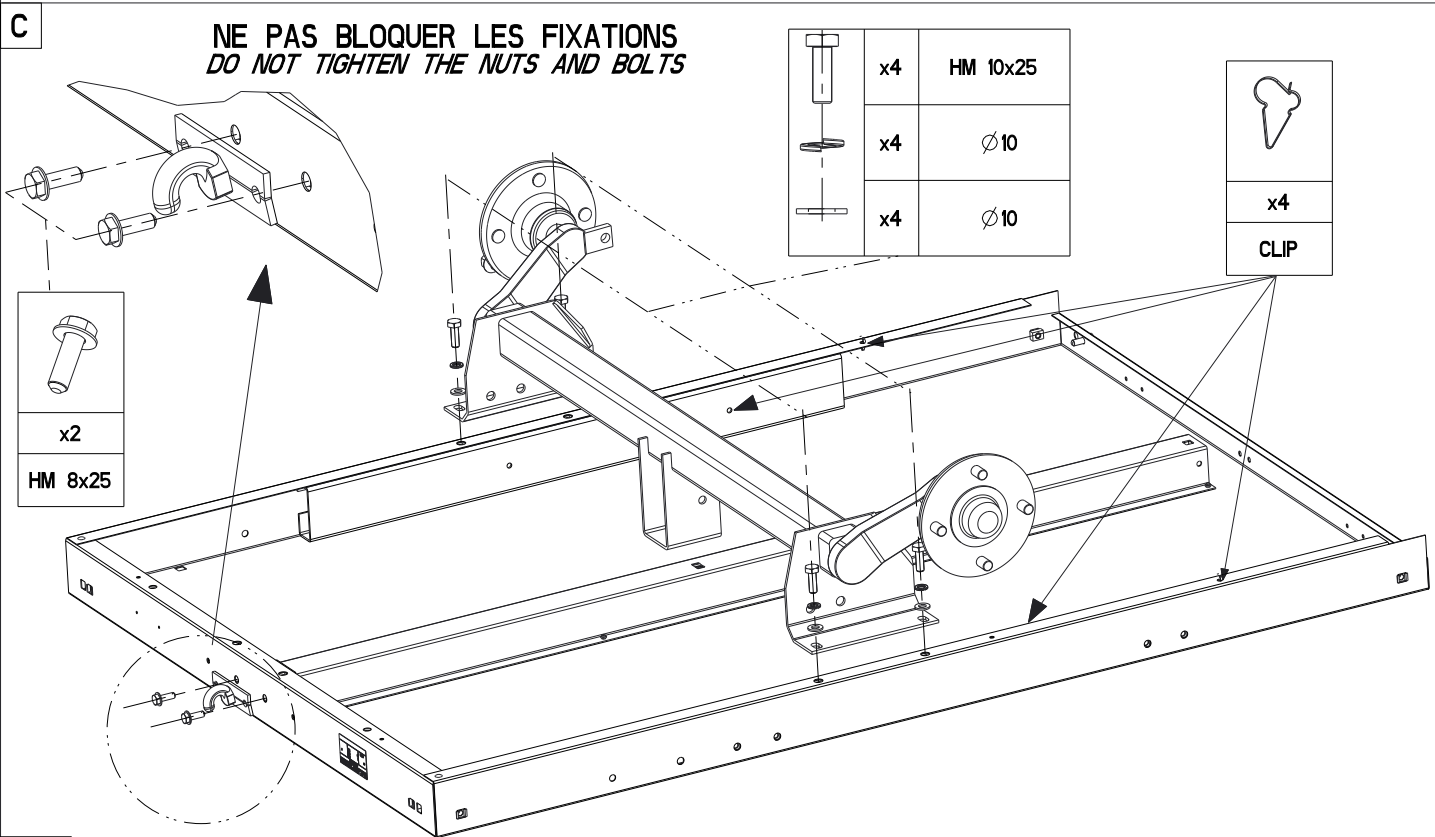
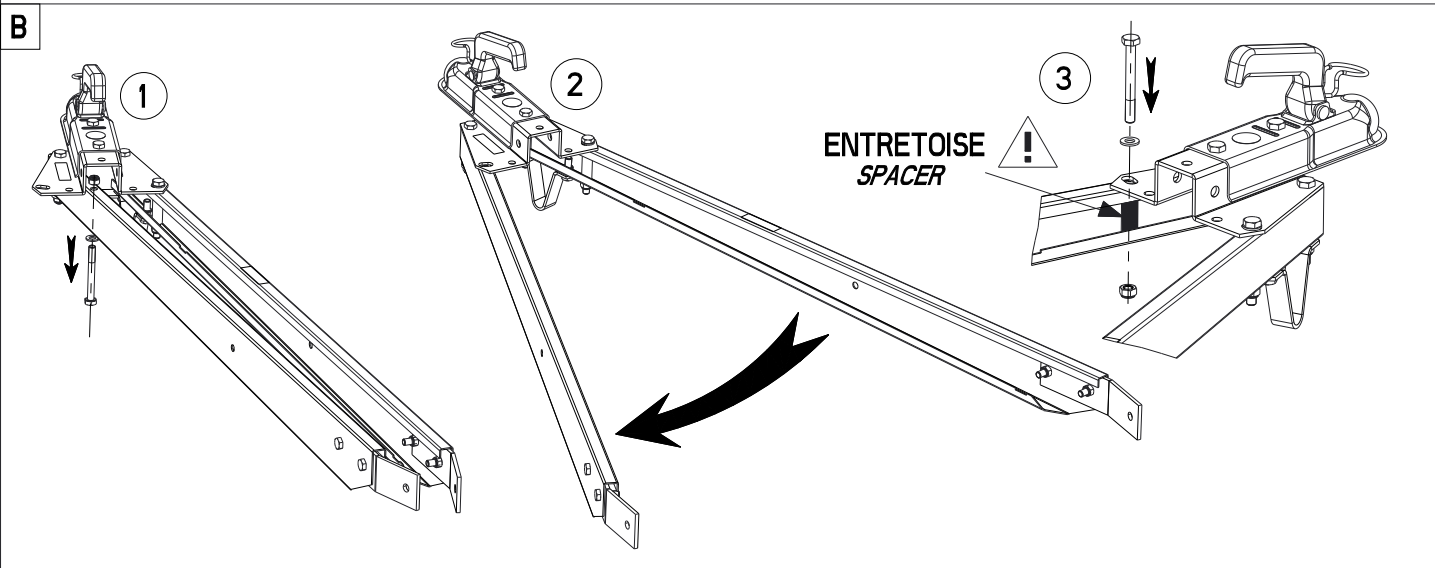
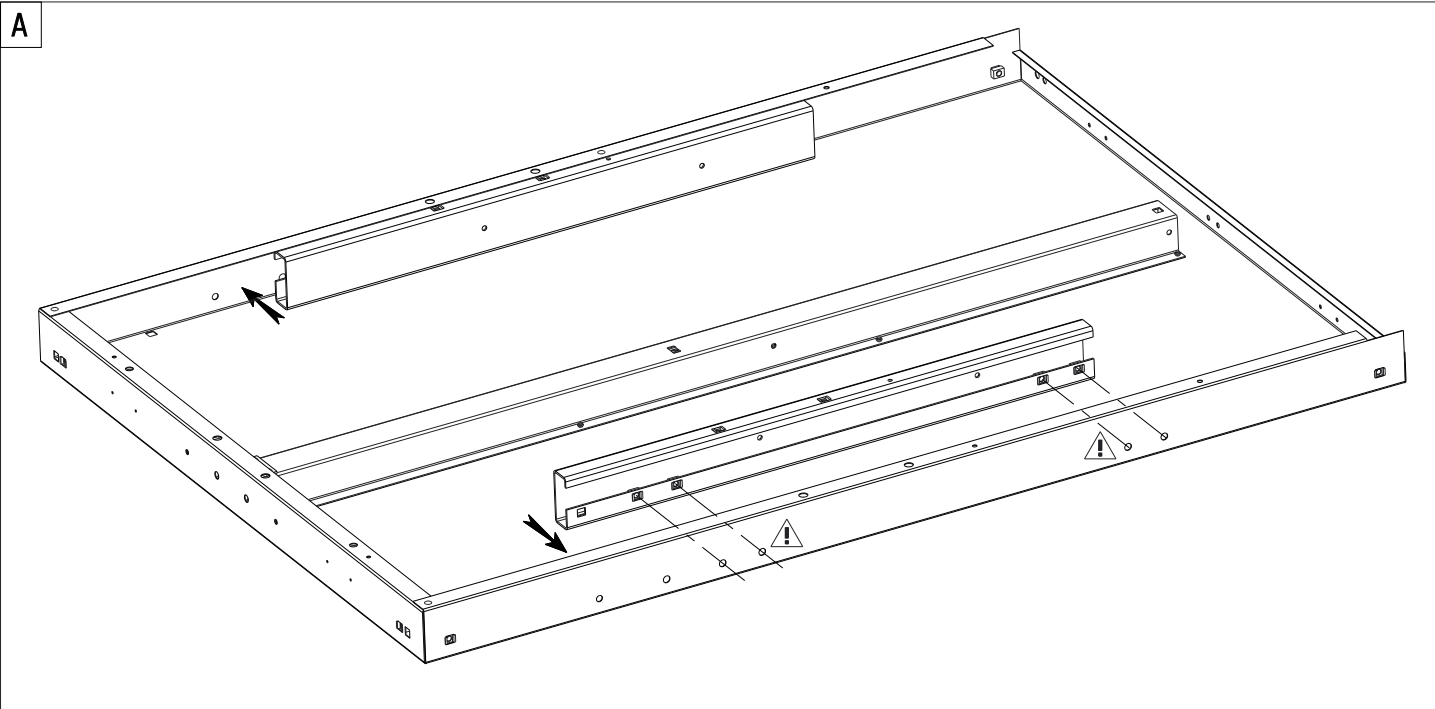

D

**BLOQUER LES FIXATIONS APRES  
CETTE OPERATION  
TIGHTEN ALL NUTS AND BOLTS  
AT THIS STAGE**

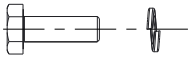
	
x2	x2
HM 10x25	∅10

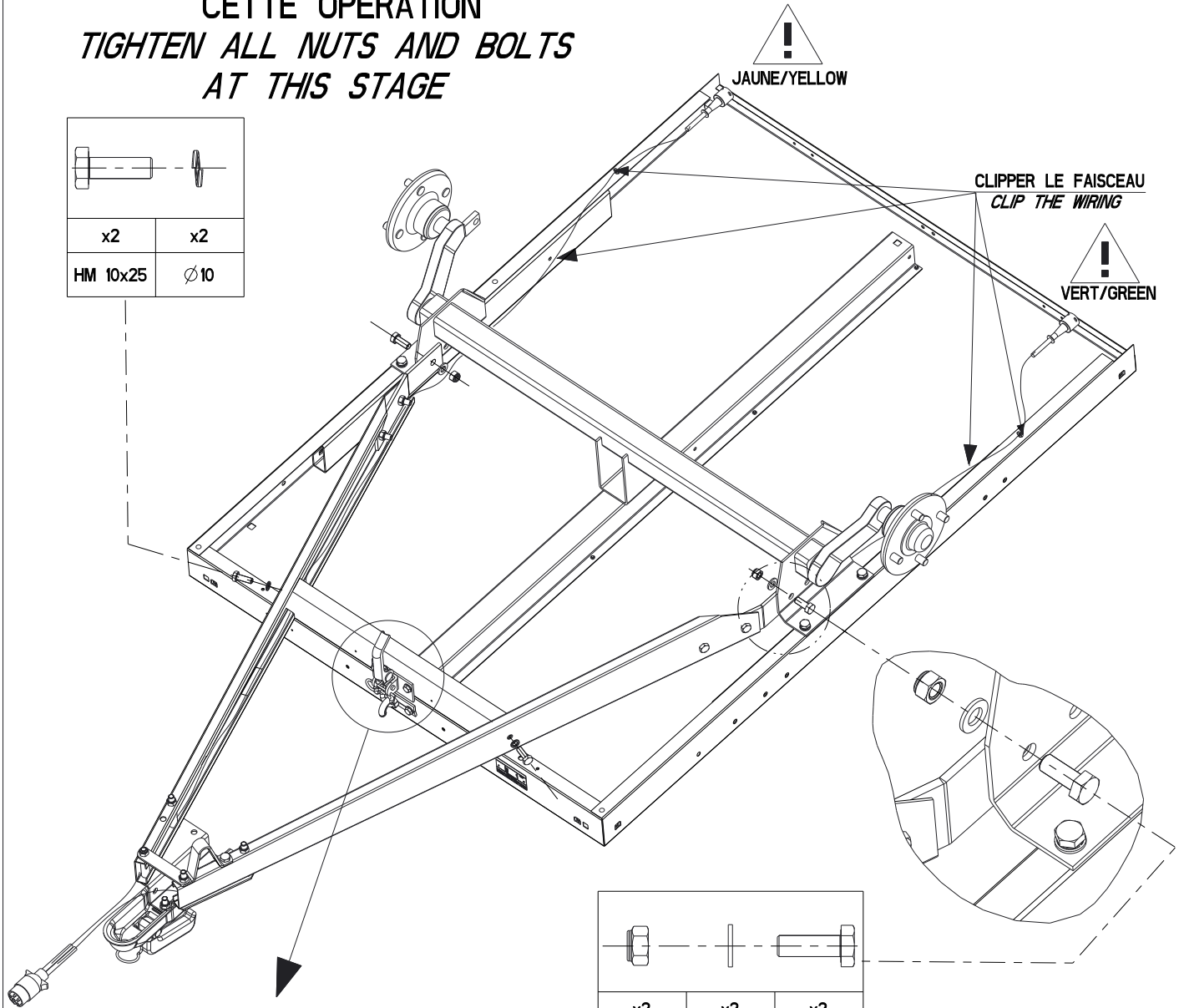

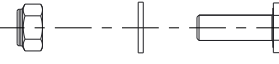

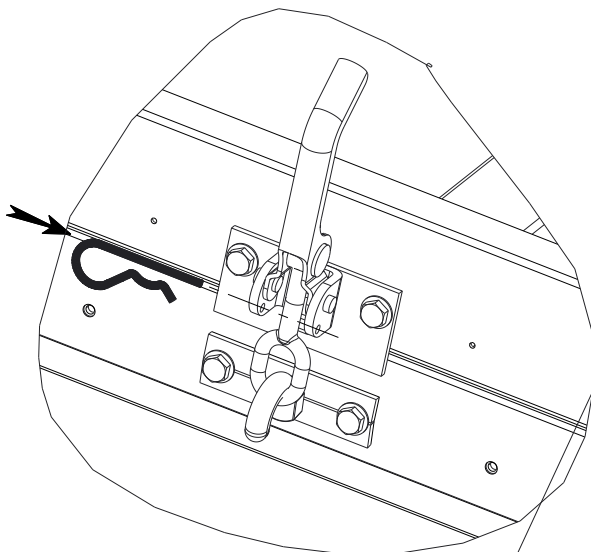
		
x2	x2	x2
FR HM 12	∅12	HM 12x30

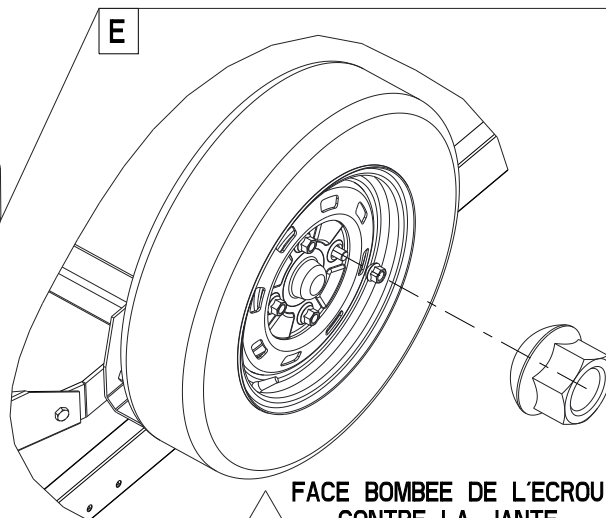

**REGLER LA POIGNEE DE FERMETURE  
ET VERROUILLER  
ADJUST TO FIT THE BOLT  
HANDLE AND LOCK**





x8
VIS DE ROUE / WHEEL BOLT
OU

x8
ECROU DE ROUE / WHEEL NUT

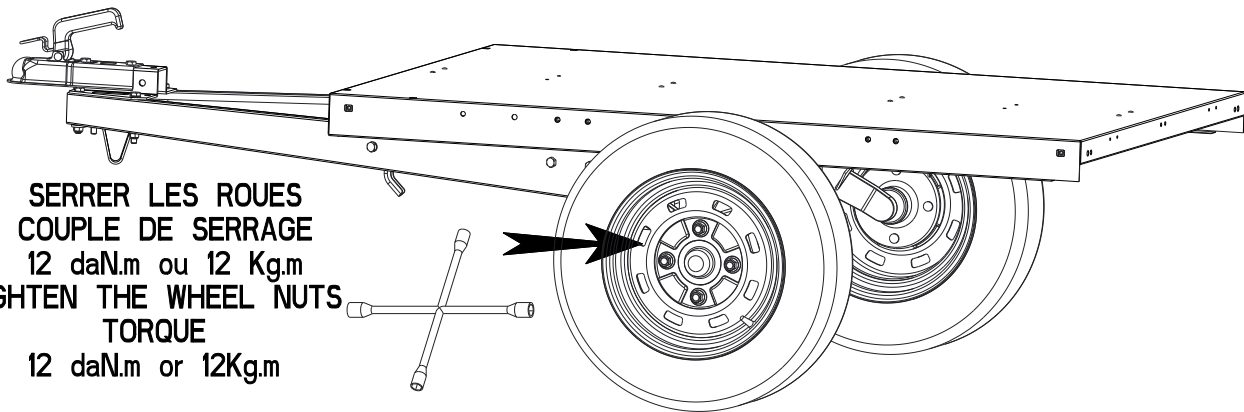
F

1 **RETOURNER LA REMORQUE**  
*TURN OVER THE TRAILER*

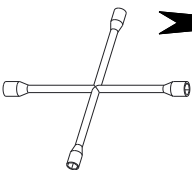

2 **SERRER LES ROUES**  
**COUPLE DE SERRAGE**  
12 daN.m ou 12 Kg.m  
**TIGHTEN THE WHEEL NUTS**  
**TORQUE**  
12 daN.m or 12Kg.m



POUR LES REMORQUES EQUIPEES D'UNE ROUE JOCKEY DE SERIE, VEUILLEZ VOUS REPORTER A LA NOTICE DE MONTAGE "ROUE JOCKEY" OPERATION 3 (JOINTE), AVANT D EFFECTUER LES OPERATIONS SUIVANTES.

*FOR TRAILER WITH JOCKEY WHEELS FITTED AS STANDARD PLEASE REFER TO THE ASSEMBLY INSTRUCTIONS FOR " JOCKEY WHEELS " OPERATION 3 BEFORE CARRYING THE FOLLOWING OPERATION.*

G

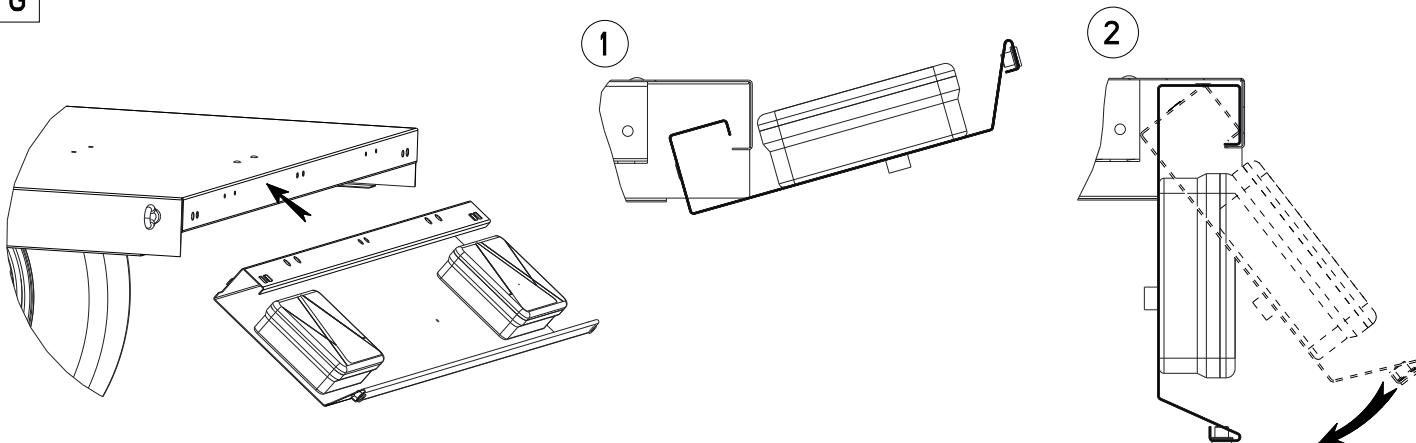

H

**NE PAS BLOQUER LES FIXATIONS**  
**DES OPERATIONS SUIVANTES**

**DO NOT TIGHTEN THE NUTS AND**  
**BOLTS DURING THE NEXT SEQUENCES**

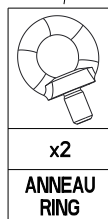
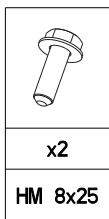
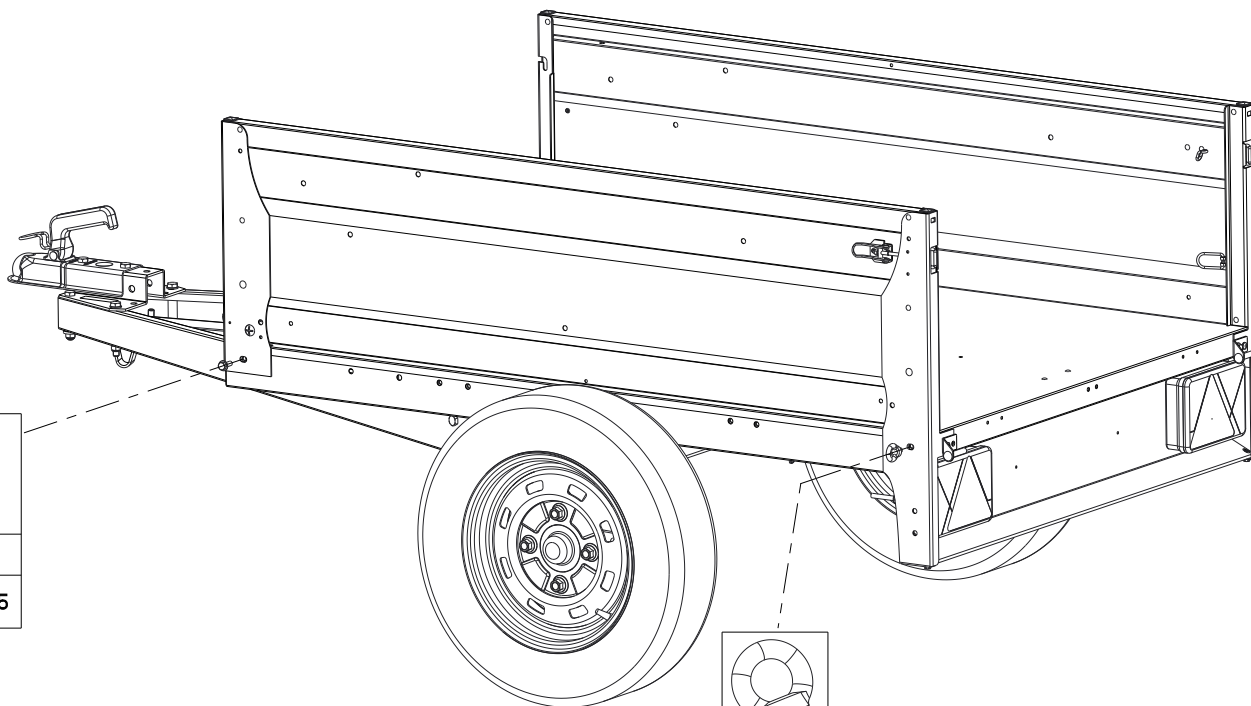



I

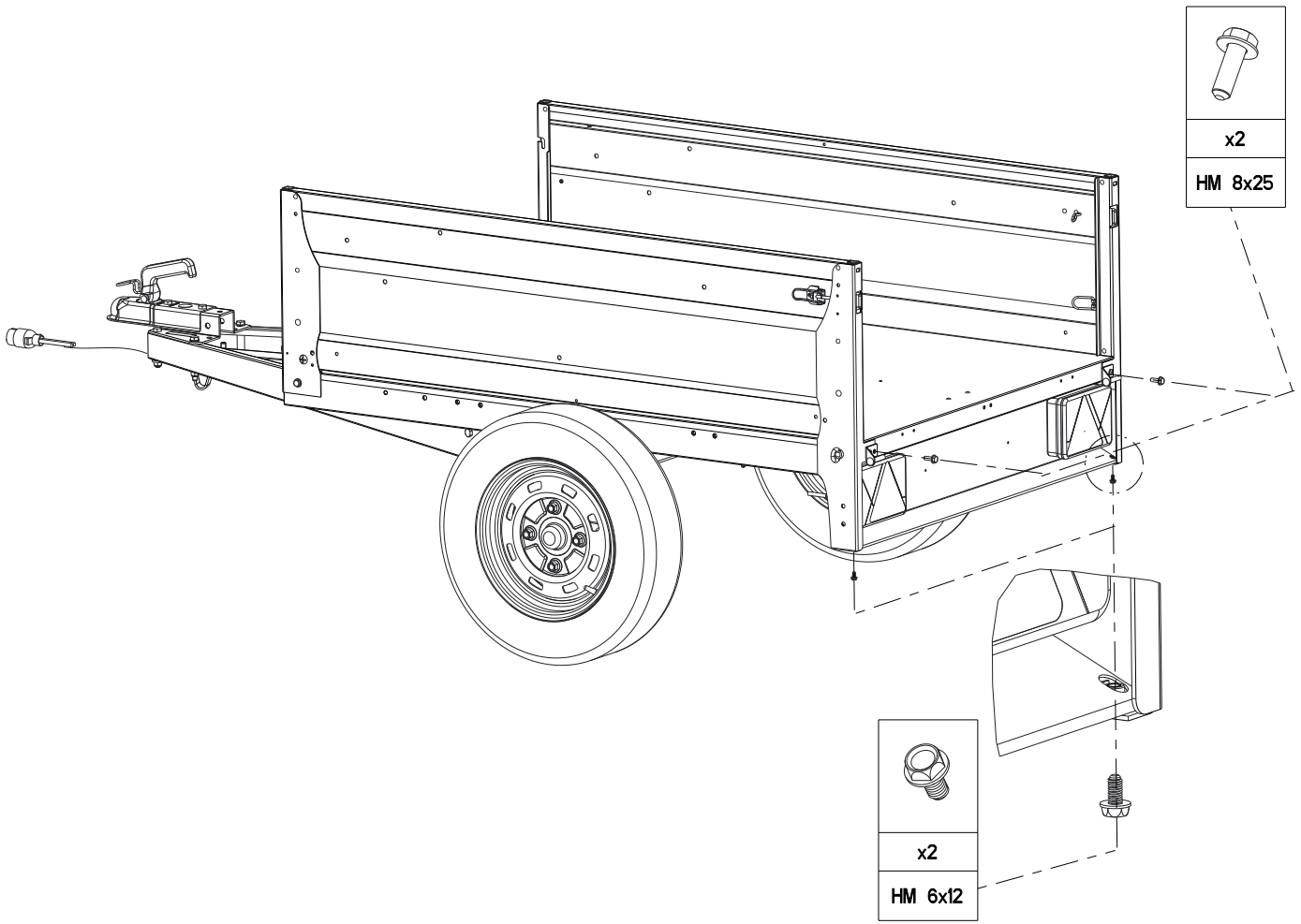

J

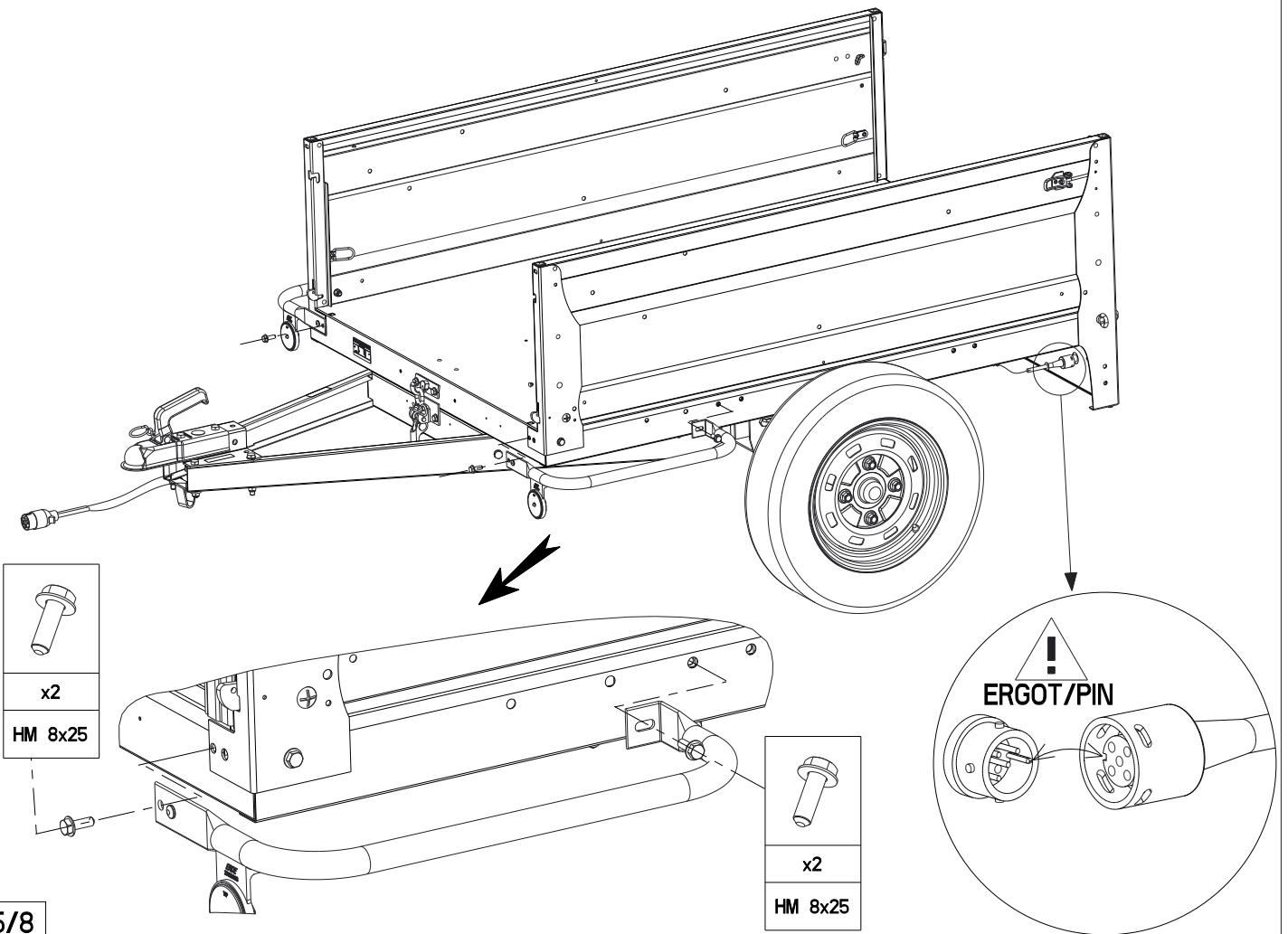

5/8

K

## SYSTEME CLIC/CLAC

CE SYSTEME CLIC/CLAC DOIT ETRE UTILISE  
EXCLUSIVEMENT EN POSITION FERMEE ET  
VERROUILLEE OU RIDELLE AVANT COMPLETEMENT  
RETIREE. L'UTILISATION EN POSITION INTERMEDIAIRE  
N'EST PAS AUTORISEE.

MONTER LES MOLETTES  
UNIQUEMENT SUR 158.2  
ASSEMBLE THE TOOTHED WHEEL  
ONLY ON 158.2 MODELS

## CLICK/CLACK SYSTEM

THE "CLICK-CLACK" SYSTEM MUST BE USED  
EITHER COMPLETELY CLOSED AND SECURED  
WITH THE RCLIP, OR PERFECTLY STORED AND  
SCREWED ALONG THE SIDE PANEL.

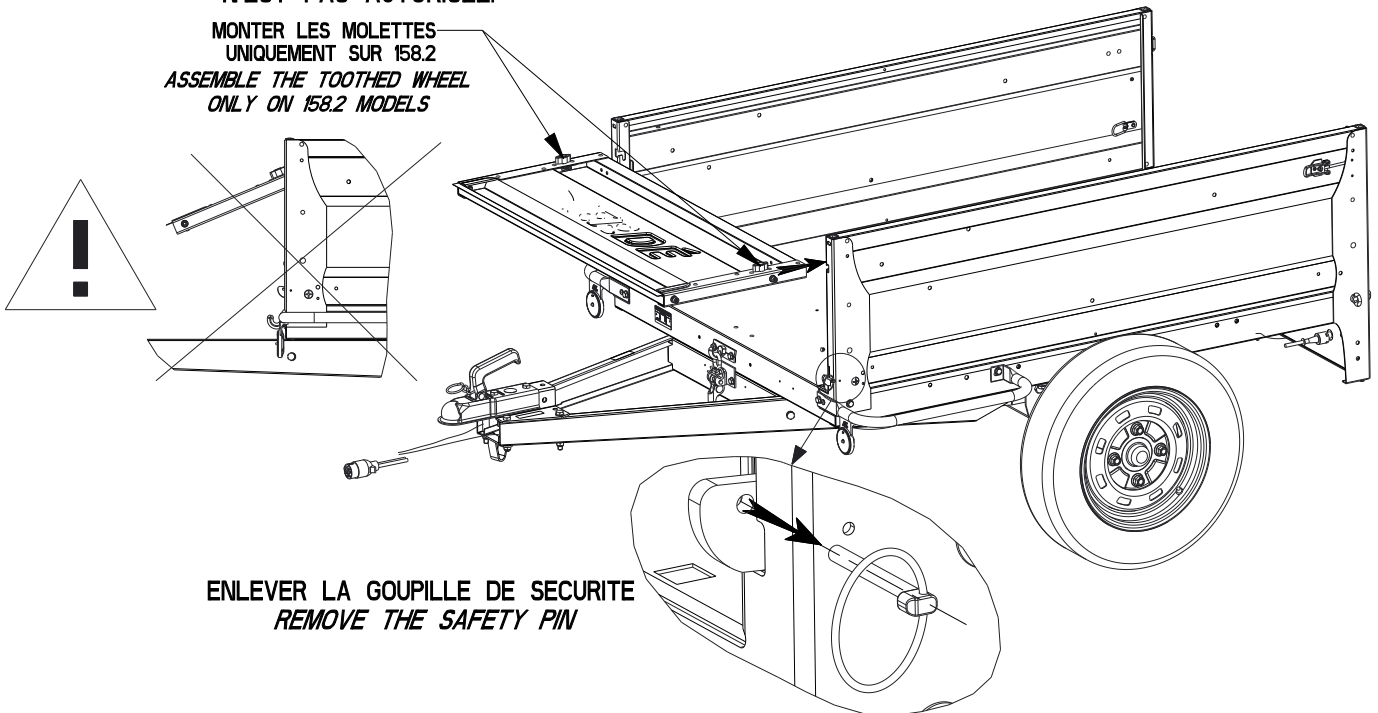

L

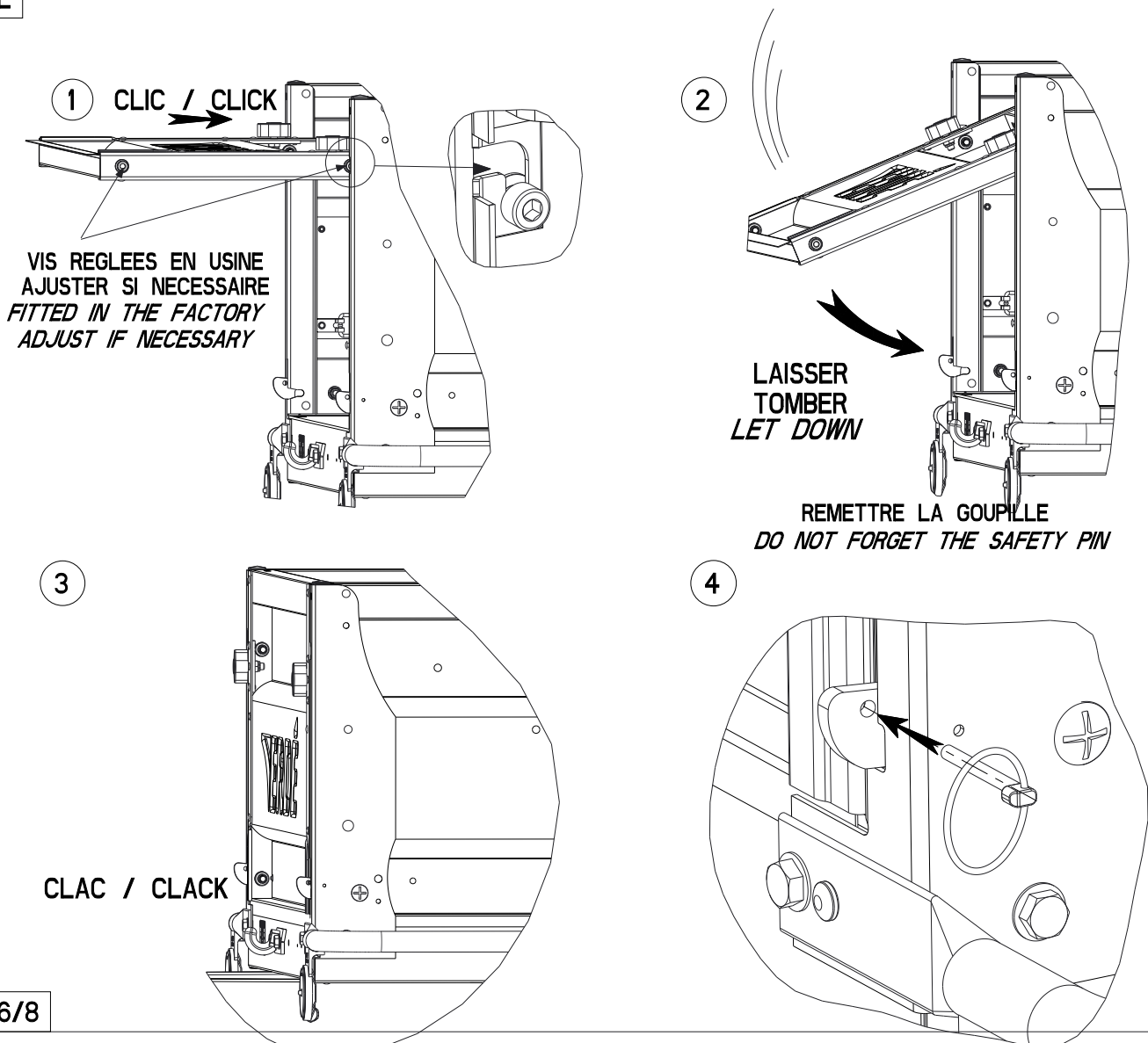

M

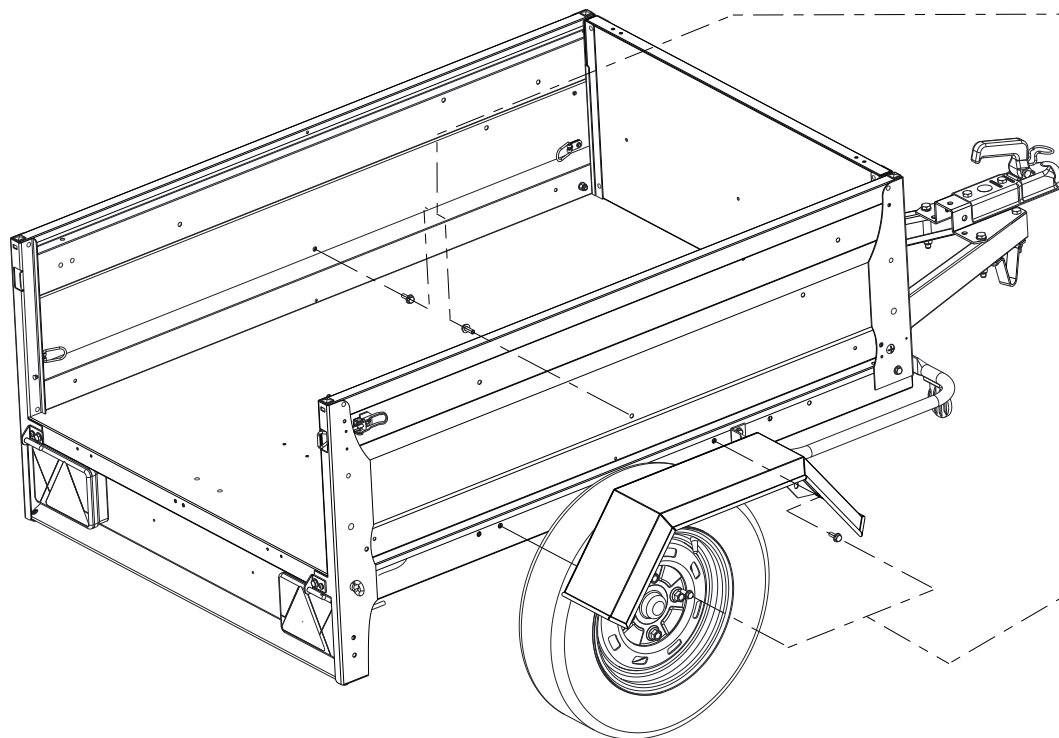

x2

HM 8x25



x4

HM 8x25

N

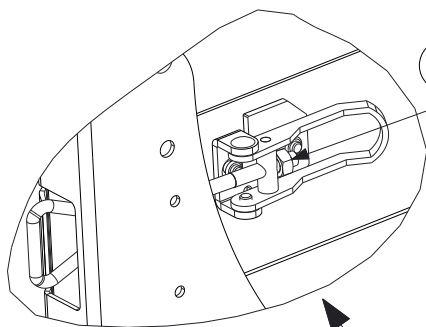

**2** REGLER LES SAUTERELLES  
ET BLOQUER LES ECROUS  
*ADJUST THE LEAVERS  
AND TIGHTEN THE NUTS AND BOLTS*

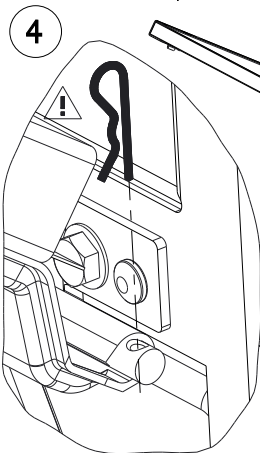
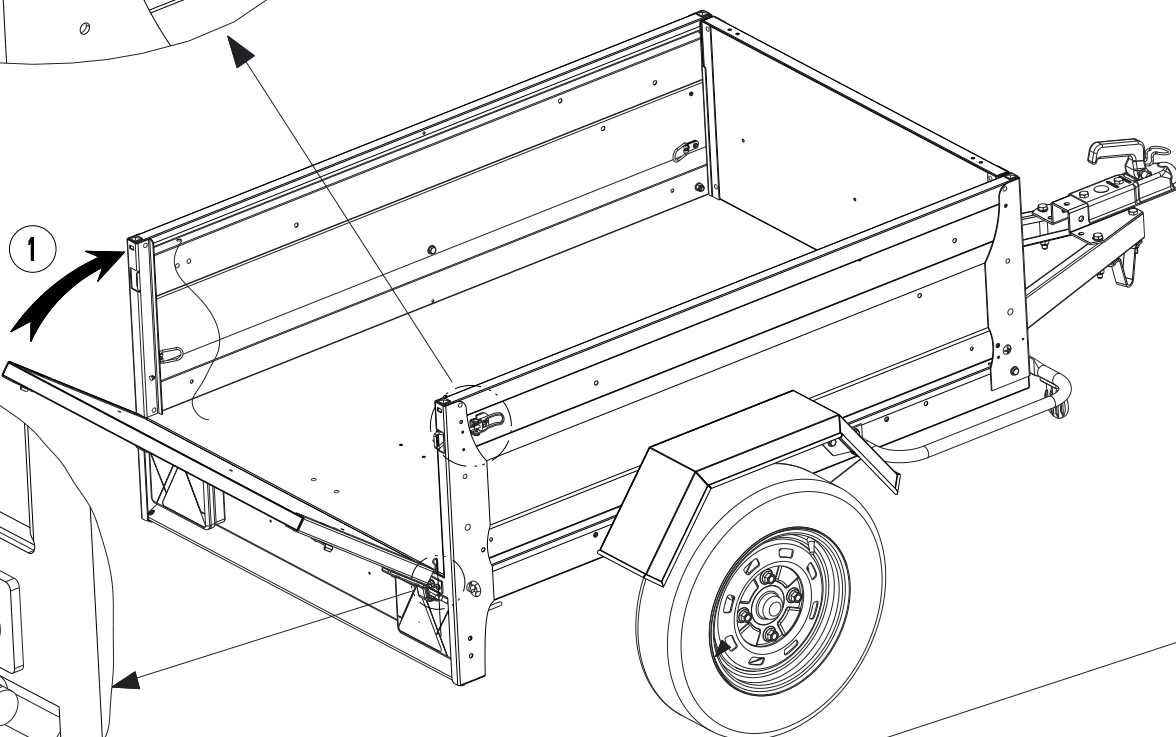

**3** BLOQUER TOUTES LES FIXATIONS EN COMMENCANT  
PAR LES VIS LATERALES.  
NE PAS OUBLIER DE SERRER LES VIS DES GONDS  
APRES AVOIR RETIRE LA RIDELLE ARRIERE.  
*TIGHTEN ALL THE NUTS AND BOLTS STARTING  
WITH THE SIDE PANELS ONES DO NOT FORGET TO  
TIGHTEN THE HINGE SCREWS WHILST TAKING OUT  
THE REAR PANEL*

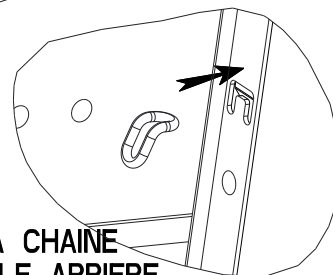

**0** INSERER LA CHAINE  
SUR LA RIDELLE ARRIERE  
*FIT THE CHAIN AS SHOWN  
ON THE REAR PANEL*

# OUVERTURE DE LA RIDELLE AVANT ET FIXATION SUR RIDELLE LATÉRALE HOW TO OPEN THE FRONT DOOR AND INSTALL IT ON THE SIDE PANEL

1

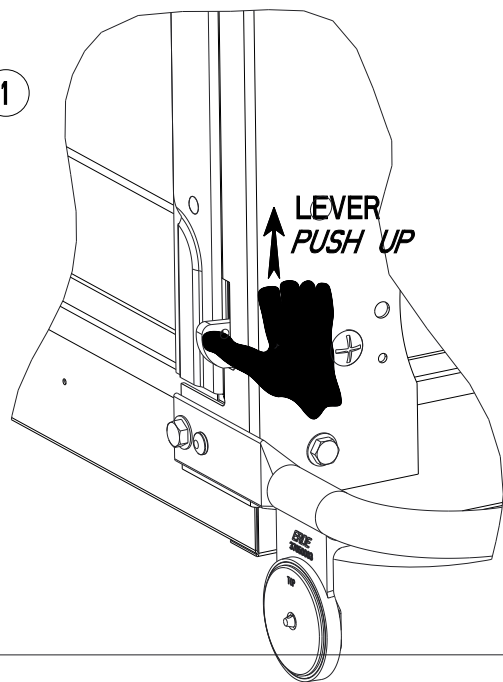

2

TIRER  
PULL

MAINTENIR  
HOLD

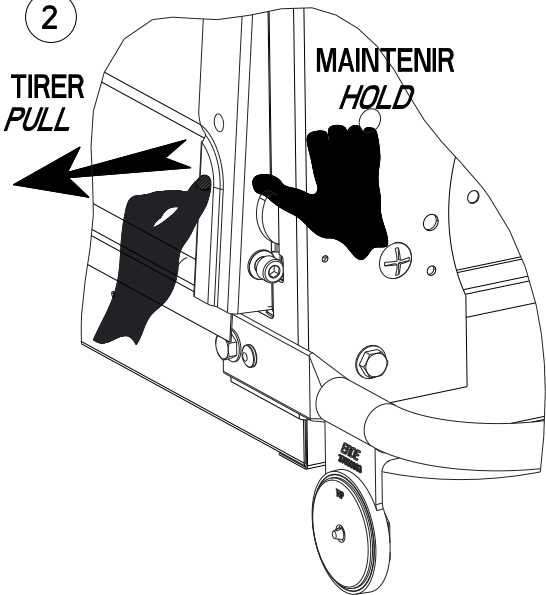

1

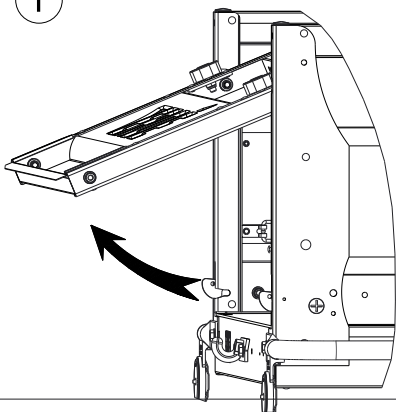

2

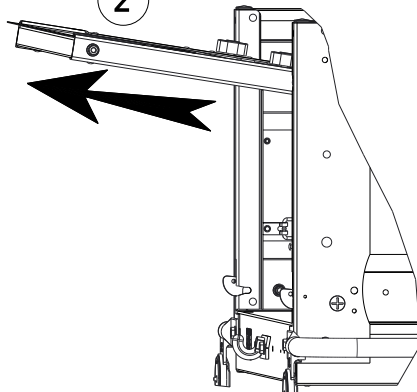

3

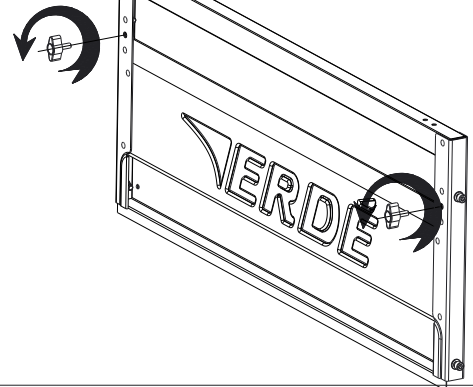

2 APPUYER SUR LA RIDELLE AVANT  
POUR FAIRE COINCIDER LES TROUS.  
PRESS DOWNWARDS TO ALIGN HOLES

